



I N T R O D U C T I O N

This manual contains a brief description of the principal data relating to the car, and information concerning its normal use and maintenance.

To obtain the best possible results from the car, we strongly recommend that users should follow our instructions. For all servicing and repairs, we advise clients, in their own interest to apply to our distributors or agents who will arrange for the efficient, speedy and accurate execution of all servicing and repairs.

WHEN ORDERING SPARE PARTS, PLEASE STATE CHASSIS AND ENGINE NUMBERS.

IDENTIFICATION NUMBERS OF CAR

A special identification number is marked on each car;

AM 109/S ☆ ..... ☆

This number is stamped on the left hand side of the crossmember between the Company's star symbol.

Engines are numbered consecutively and the engine number is stamped on the clutch bell housing, opposite the starter motor, for ease of reference, these numbers are given also on a Maserati plate which is fixed inside the engine compartment. These are the only marks used for the identification of the car for purpose of sale, and as required by law. They are also indicated in the certificate of origin and in the log book.

SPECIFICATION AND GENERAL DATA

ENGINE

Number of cylinders .....	6
Bore and stroke .....	86 x 100 mm
Swept volume of single cylinder .....	580,88 cc.
Total cylinder capacity .....	3485,29 cc.
B.H.P. 5500 r.p.m. ....	235 HF.
Tax rating .....	33 HP.



I N T R O D U C T I O N

#233

MISTRAL

Owner's Manual

This Manual contains a brief description of the principal data relating to the car, and information concerning its normal use and maintenance.

To obtain the best possible results from the car, we strongly recommend that users should follow our instructions. For all servicing and repairs, we advise clients, in their own interest to apply to our distributors or agents who will arrange for the efficient, speedy and accurate execution of all servicing and repairs.

WHEN ORDERING SPARE PARTS? PLEASE STATE CHASSIS AND ENGINE NUMBERS.

IDENTIFICATION NUMBERS OF CARS

A special identification number is marked on each car:

3700 c.c AM	109	☆	.....	☆
4000 c.c AM	109/A1	☆	.....	☆

This number is stamped on the left hand side of the crossmember, between the Company's star symbol.

Engines are numbered consecutively and the engine number is stamped on the clutch bell housing, opposite the starter motor.

For ease of reference, these number are given also on a Maserati plate which is fixed inside the engine compartment. These are the only marks used for the identification of the car for purpose of sale, and as required by law. they are also indicated in the certificate of origin and in the log book.

SPECIFICATION AND GENERAL DATA

<u>E N G I N E</u>	<u>3700 cc</u>	<u>4000 cc</u>
Number of cylinders . . . . .	6	6
Bore and stroke . . . . .	86 x 105 mm	88x110
Swept volume of single cylinder . . . . .	615 c.c.	669 c.c.
Total cylinder capacity . . . . .	3,692 c.c.	4014 c.c.
B. H. P. 5500 r.p.m. . . . .	245 h.p.	255 h.p.
Tax rating . . . . .	36 h.p.	37 h.p.

**MASERATI INFORMATION EXCHANGE**  
P. O. BOX 772  
MERCER ISLAND, WASHINGTON 98040 U.S.A.  
(206) 455-4449



Light alloy cylinder block with special inset cast iron liners.  
Light alloy cylinder head with overhead valves and hemispherical combustion chambers.

Dynamically and statically balanced seven bearing crankshaft with lead indium shells.

Cast steel 'H' section connecting rods with lead indium shells and bearings, and bronze bushes in the big ends.

Light alloy pistons with two compression rings and two scraper rings. Fully-damped flywheel on crankshaft.

Light alloy inlet manifold with water circulation for preheating of mixture.

#### VALVE TIMING

Inclined overhead valves operated by two overhead camshafts, with triplex chain drive, equipped with chain tensioner.

The camshafts control the valves direct through cast iron tappets. The valves are adjusted by means of casehardened steel pads.

Valve clearance is 0,15 mm for inlet, with tappet resting on heel of cam and 0,30 mm for exhaust. Measurements to be taken with cold engine.

Inlet valve lift .....at T.D.C..... 1,2 mm  
Exhaust valve lift .....at T.D.C..... 0,9 mm

#### FUEL SYSTEM (INJECTION TYPE)

The LUCAS equipment used, with indirect injection into the inlet manifolds, comprises a petrol pump, distributor and governor.

#### CHOKE

To facilitate starting the engine when cold, and especially during the winter, an additional quantity of petrol and air must be supplied to allow the engine to warm up smoothly. This is controlled by the choke which increases the volume to three times that of the normal supply.

The driver should gradually reduce the richness of this mixture by progressively using less choke until the engine is at running temperature.



- LUCAS DISTRIBUTOR - - FUEL SYSTEM -

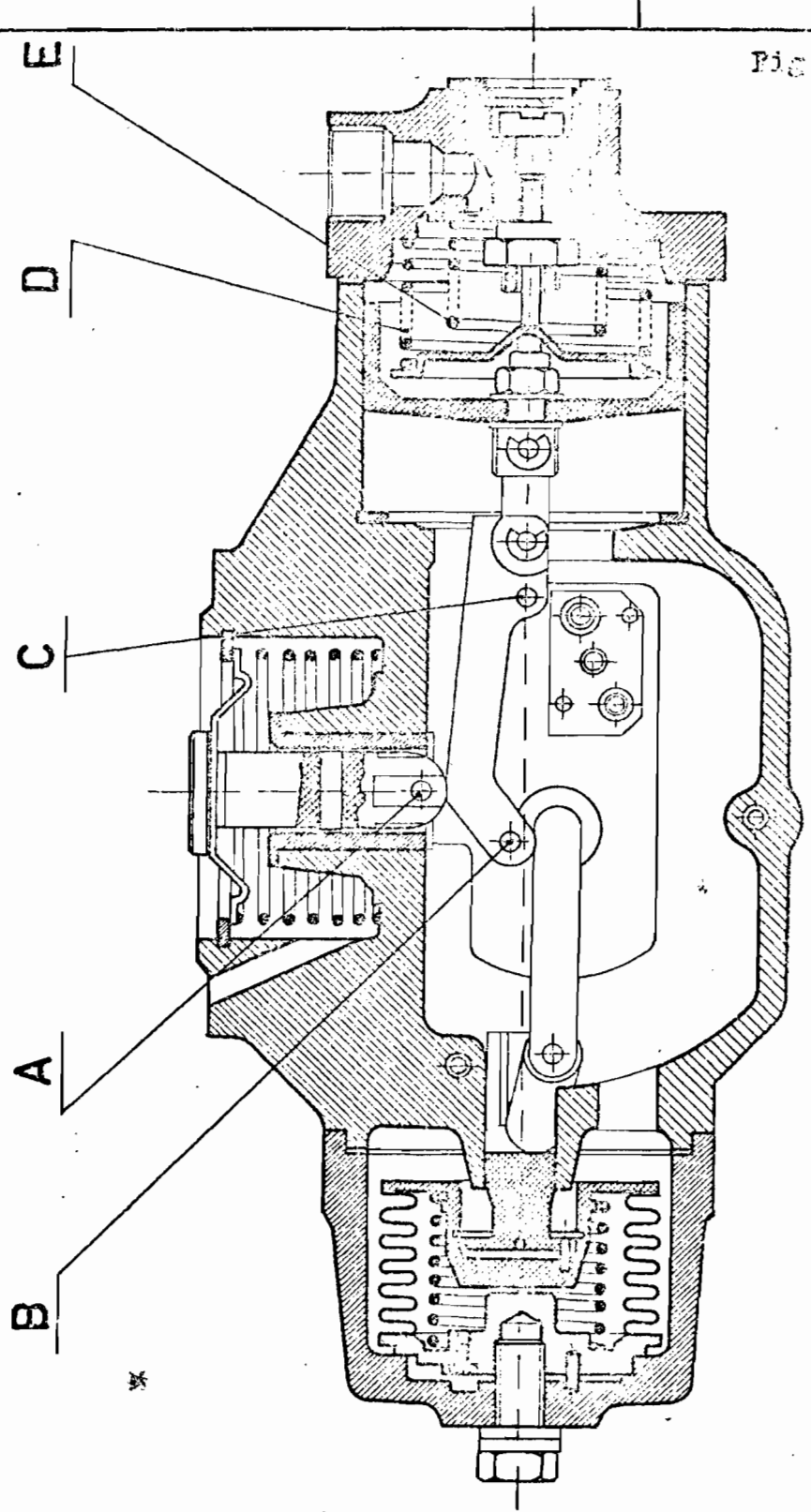

Fig. 1

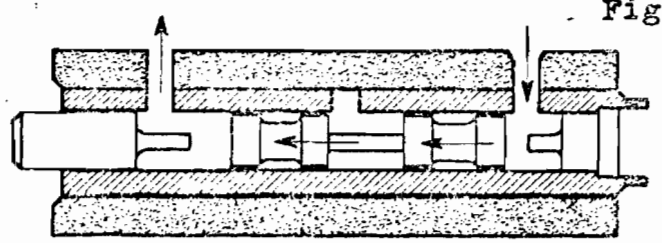

Fig. 2



### LUBRICATION

Pressurised lubrication of all main parts of the engine is by a pump mounted direct onto the crankshaft.

The pump draws the oil via a filter from the engine sump, and conveys it to the assemblies to be lubricated. The two oil filters are housed in an oil cooler, in which cold water from the radiator and the oil to be filtered circulate through copper ducts.

The oil cooler serves a dual purpose:

- 1) It heats the oil when cold by using the water which bypassing the thermostat, does not pass through the radiator.
- 2) It reduces the temperature of the oil when hot by using the cooled water from the radiator.

The filter is on the right hand side of the sump and it can be removed from underneath the car.

The normal oil pressure is 3 to 5 kg per sq cm. This pressure is governed by a control valve mounted on the filter housing itself.

The oil filler is on the cylinder head.

The oil level can be checked by means of the dipstick situated on the left hand side of the sump, below the exhaust manifold.

The capacity of the sump is 16 pints.

### COOLING SYSTEM

The engine is cooled by the circulation of water. The circulation is controlled by a centrifugal pump and fan of the electromagnetic type, with operation controlled by thermostat on the radiator. The fan operates above a temperature of 72°/85°. The flow of water through the radiator is also regulated by means of a thermostat mounted in the cylinder head. This device facilitates the heating of the engine, especially when starting from cold. A water temperature gauge is situated on the instrument panel.

The temperature of the water must not exceed 90°.

The drain tap will be found beneath the radiator.

The total quantity of cooling water is approximately 25 pints.

### IGNITION

Ignition is by a distributor situated at the front of the engine, on the left hand side. It is controlled by a helical gear coupling and it is battery-fed.

MARELLI S 109 A 12 V. 15° Distributor with automatic advance.

Left hand rotation, as viewed from above.

Static advance 8°.

Range of automatic advance to 30° ( on the crankshaft )

Max. total ignition advance 38° ( on the crankshaft )

Order of ignition : 1 - 5 - 3 - 6 - 2 - 4

Contact breaker gap = 0.015"

Sparking plugs gap = 0.020"

Diameter and pitch of long reach plugs : 14 x 1,25 M

MARELLI coils N° 2 type B Z R 201 A

Sparking plugs for normal use :

BOSCH	W 225 T 28
AUTOLITE	AG 2 = CHAMP N 4
LODGE	HLN
CHAMP	N 4

Sparking plugs for heavy duty :

BOSCH	W 240 T 28
AUTOLITE	AG 12
LODGE	2HLN

### ENGINE MOUNTING

The engine is offset at an angle of 4° in relation to the chassis, with a displacement of 48 mm to the right and it rests on 4 silentblocs, two for the engine and two for the gear box. longitudinal inclination = 1° 47'

### CLUTCH

Flexible single dry plate, with hydraulic control by two pumps one on the pedal  $\varnothing$  3/4" and the other on the clutch  $\varnothing$  7/8". The pedal travel is regulated by a nut on the receiving pump.

### GEAR BOX

Five forwards speeds and reverse. Synchronesh on all forward gears. Gears in constant engagement. Direct control lever mounted on centre of gear box. To check the oil level in the gear box a long pipe arrive under bonnet. The dipstick, that is not signed, must touch oil only at the end.

GEAR RATIOS

1st ratio	0,347	=	3,00
2nd "	0,586	=	1,705
3rd "	0,806	=	1,24
4th "	1	=	1
5th overdrive	1,18	=	0,85
Reverse	0,315	=	3,17

REAR AXLE

Rigid rear axle with hypoid bevel coupling.

Standard reduction ratio :  $13/46 = 3,54 = 0,28$

This may be substituted by :  $13/49 = 3,77 = 0,265$

" :  $13/43 = 3,31 = 0,302$

" :  $11/45 = 4,09 = 0,244$

The rear axle is connected to the chassis by semi elliptic springs.

CHASSIS

Main dimension:

Track width, at ground level front: 55 inches

Track width, at ground level rear : 53 1/2 inches

Wheelbase 94 inches

Weight of car, unloaded (approx) 25 cwt. 15 lbs.

The chassis, which is exceptionally strong, consists of box section side-members and cross-members and tubular crosspieces.

FRONT SUSPENSION

Upper and lower links, adjustable type with large coil springs and telescopic shock-absorbers. Anti roll bar.

REAR SUSPENSION

Semi elliptic springs with telescopic shock-absorbers and anti roll bar.

STEERING

The steering, which is adjustable, is mounted on ballbearings.

Flexibly-coupled steering wheel to eliminate vibration.

Steering rods symmetrical with steering box assembly.

The position of the steering wheel is adjustable on splines, controlled by a small hand wheel.

B R A K E S

Dual hydraulic braking system, with servo assistance. Braking of front wheels entirely independent of that of rear wheel. By two Girling vacuum-type units.

The front brakes are of the Girling disc type, diam. 12"; friction surface 310 sq. ins.

The rear brakes are also of the Girling disc type,  $\phi$  291 mm. 11 1/4" with friction surface of 248 sq. ins.

Adjustment of clearance (due to wear of brake linings) is automatic. The handbrake operates on the rear wheels only and is a mechanical system.

W H E E L S

Spoke type 650 x 15" with tapered hub, locked by wing nuts.

F R O N T   A L I G N M E N T

The toe-in of the wheels, measured on the rims at the height of the hubs, is 2 - 3 mm. ( 5/64" - 1/8" )

The camber, in the straight ahead position, is 1°.

The inclination of the plane in which the wheels act as springs, in the vertical-transversal plane, or angle of incidence of the pins is 6°. (Caster).

The transversal inclination king pin angle (seen from the front of the pins) is 7° 30'.

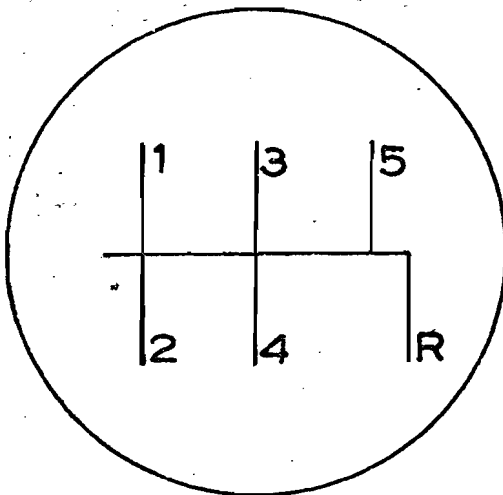

Position of gears in box : S5 - 20



TYRES

Front and rear : Firelli 205 x 15"

TYRE PRESSURE (cold):

Recommended tyre pressure  
for normal touring :

Front	31 p.s.i.
Rear	33 p.s.i.

Tyre pressure for high speed  
driving (over 100 m.p.h.) :

Front	35 p.s.i.
Rear	38 p.s.i.

PETROL TANKS

Two tanks, situated at the sides of the car at the rear.  
Connected by a 1 3/16" tube below for transfer of the petrol,  
and a 9/16" tube above to balance the pressure.

ELECTRICAL INSTALLATION

Battery: Behind left hand seat and easily accessible for  
inspection.

Capacity: 62 amp/hour. Voltage 12 V.

Alternator: Prestolite type, with mechanical voltage regula-  
tor. Situated on left hand side of engine and controlled by  
drive shaft with adjustable V-belt.

Normal rating 450 watts. Direction of rotation as seen from  
driver's seat: right hand.

Starter motor: Marelli type SM 271 A 1,3 h.p.

Horn: Two Piann pneumatic horns with electric compressor type  
MC/1 and horns TA/2 with pushbutton control in centre of  
steering wheel.

Fuses: The 12 fuses of the electrical installation are grouped  
together on a square fuse board under the instrument panel,  
on the right hand side.

TYRES

Front and rear : Pirelli 205 x 15"

## TYRE PRESSURE (cold):

Recommended tyre pressure  
for normal touring :

Front 31 p.s.i.  
Rear 33 p.s.i.

Tyre pressure for high speed  
driving (over 100 m.p.h.) :

Front 35 p.s.i.  
Rear 38 p.s.i.

PETROL TANKS

Two tanks, situated at the sides of the car at the rear.  
Connected by a  $1 \frac{3}{16}$ " tube below for transfer of the petrol,  
and a  $9/16$ " tube above to balance the pressure.

ELECTRICAL INSTALLATION

Battery: Behind left hand seat and easily accessible for  
inspection.

Capacity: 62 amp/hour. Voltage 12 V.

Alternator: Prestolite type, with mechanical voltage regulator.  
Situated on left hand side of engine and controlled by  
drive shaft with adjustable V-belt.

Normal rating 450 watts. Direction of rotation as seen from  
driver's seat: right hand.

Starter motor: Marelli type SM 271 A 1,3 h.p.

Horn: Two Fiamm pneumatic horns with electric compressor type  
MC/1 and horns TA/2 with pushbutton control in centre of  
steering wheel.

Fuses: The 12 fuses of the electrical installation are grouped  
together on a square fuse board under the instrument panel,  
on the right hand side.

Axle ratio 13/46 = 0,2825 - 3,54  
 Tyres - 205 x 15" average circumference 84 inches  
 SPEED - MILES/h (with gear box S5 20)

Engine revs.	1st Gear 3	2nd Gear 1,705	3rd Gear 1,24	4th Gear 1	5th Gear 0,85
1000	7,4	13,1	18	22,3	26,3
1500	11	20	27	33,5	39
2000	14,6	26	36	45	53
2500	18,3	33	45	56	66
3000	22	39	54	67	79
3500	25,6	46	63	78	92
4000	29,2	52	72	89	105
4500	32,9	59	81	100	118
5000	36,6	65	90	117	131
5500	40,3	66	99	123	145
6000	44	72	108	134	158

Axle ratio 12/49 = 0,265 - 3,77  
 Tyres - 205 x 15" average circumference 84 inches  
 SPEED - MILES/h (with gear box S5 20)

Engine revs.	1st Gear 3	2nd Gear 1,705	3rd Gear 1,24	4th Gear 1	5th Gear 0,85
1000	7	12,3	16,9	21	24,7
1500	10	18,5	25	31	36
2000	14	23	34	42	49
2500	18	31	42	52	61
3000	21	37	51	63	72
3500	25	43	59	73	85
4000	28	49	68	84	99
4500	32	55	76	94	110
5000	35	62	84	105	121
5500	39	68	93	115	133
6000	42	74	101	126	144

At high speed the above specifications are to be multiplied by the tyre expansion coefficient which is caused by the centrifugal force.

AUTOMATIC TRANSMISSION

This car can be fitted with the BORG WARNER type 8 automatic transmission. The shift lever is centrally fitted and has the following control position:

- P Parking position with locking action on wheels.
- R Reverse gear position, in which the rear lamps are switched on. Transmission ratio 1 : 2.
- N Neutral position - the car can be pushed or towed.
- D2 Driving position with one automatic change in direct drive. Transmission ratio 1 : 1.47.
- D1 Driving position with two automatic changes in direct drive. Transmission ratios 1 : 2.40 and 1 : 1.47.
- L Slow driving position to be used for town or mountain driving; there is no automatic change in this position and the transmission ratio is 1 : 2.40. It is advisable to use this position only when required in order to avoid prolonged running of the engine at high speed.

The engine can be started in P or N position only.

The fluid used in the automatic transmission is AGIP ROTRA ATF.

The fluid dipstick is fitted at the right side of the engine and the transmission sump capacity is approx. 15.8 pints.

It is advisable to change the oil after each 12,000 miles.

It is also recommended not to keep the engine running at over 5000 r.p.m. for long time.

MASERATI INFORMATION EXCHANGE  
P. O. BOX 772  
MERCER ISLAND, WASHINGTON 98040 U.S.A.  
(206) 455-4449



PERFORMANCE OF THE CAR EQUIPPED WITH  
AUTOMATIC TRANSMISSION  
( ON ORDER )

Normal axle ratio  $13/43 = 3,31 = 0,302$

Tyres: 205x15" Average circumference 84 inches

SPEED - MILES/H

Engine revs.	POSITION L	POSITION D1			POSITION D2	
	0,416	0,416	0,680	1	0,680	1
1000	10	10	16	23	16	23
1500	15	15	24	34	24	34
2000	20	20	32	46	34	46
2500	25	25	40	57	40	57
3000	30	30	48	69	48	69
3500	35	35	56	80	56	80
4000	40	40	64	92	64	92
4500	45	45	72	103	72	103
5000	50	50	80	115	80	115
5500	55	55	88	126	88	126
6000	60	60	106	138	106	138

At high speed the above specifications are to be multiplied by the expansion coefficient which is caused by the centrifugal force.



FUEL SUPPLIES LUBRICATION; CONSUMPTION AND SPECIFICATION

Normal fuel consumption (according to CUNA Standard) 19 miles per gallons Motore 3700 cc. 18 MILES per GALLONS Motore 4000 cc.  
The driver is advised never to exceed 6000 r.p.m  
Autonomy : 281 miles

I T E M	CAPACI- TIES	R E M A R K S
Petrol tank	gallons 15 $\frac{1}{2}$	SUPERCORTEMAGGIORE N .O. 98/100 R.M.
Cooling system	gallons 3	Water Antifreeze- AGIP F1 ANTIFREEZE: for temperature + 10,4 Fah. for temperature - 4 Fah. for temperature - 40 Fah.
Engine sump	gallons 2	Winter : AGIP F1 RACING SAE 40 Summer ; AGIP F1 RACING SAE 50 For temperature less than + 23 Fah.use AGIP F1 RACING SAE 30
Gear box	Quart 1	AGIP F1 ROTRA HYPOID 90
Differential	Pints 2 $\frac{1}{2}$	AGIP F1 ROTRA MP SAE 90
Differential power lock	Pints 2 $\frac{1}{2}$	AGIP F1 ROTRA MP/S SAE 90
Steering box	Pint 1/3	AGIP F1 ROTRA SAE 250
Brake fluid	Pints 1 $\frac{1}{2}$	1) CASTROL WAKEFIELD GIRLING BRAKE FLUID AMBER (EXTRA HIGHT DUTY H 204/57) 2) AGIP F1 BRAKE FLUID
Clutch cilinders	Pint 1/3	AGIP F1 BRAKE FLUID
Hydraulic transmission	Gallons 2	AGIP F1 ROTRA ATF
Hydraulic steering	Pints 3 $\frac{1}{2}$	AGIP F1 ROTRA ATF
Steering Joints		AGIP F1 GREASE 15
Front hubs Bushed end bearings		AGIP F1 GREASE 33 F.D
Conditioning compressor	Pint 3/4	AGIP F1 TER 34

POSITION INDICATED ON LUBRICATION CHART

N°	1	Engine
	2	Engine
	3	Water pump
	4	Steering and suspension
	5	Universal joints
	6	Axle shafts
	7	Steering box
	8	Gear box
	9	Differential housing
	10	Pedals
	11	Handbrake
	12	Rear axle
	13	Steering box
	14	Front hubs
	15	Steering arms
	16	Starter motor
	17	Gear box
	18	Thrust clutch shaft
	19	Clutch tank
	20	Brakes tanks

SYMBOLS FOR THE LUBRICATION CHART TABLE N° X

AGIP F1 RACING SAE 30-40 : Inverno  
AGIP F1 RACING SAE 50 : Estate



1) CASTROL WAKEFIELD GIRLING BRAKE FLUID AMBER  
2) AGIP F1 BRAKE FLUID



AGIP F1 ROTRA HYPOID 90



AGIP F1 ROTRA SAE 250



AGIP F1 GREASE 15



AGIP F1 GREASE 33 F.D



AGIP F1 BRAKE FLUID



AGIP F1 ROTRA NP SAE 90



- LUBRICATION DIAGRAM -

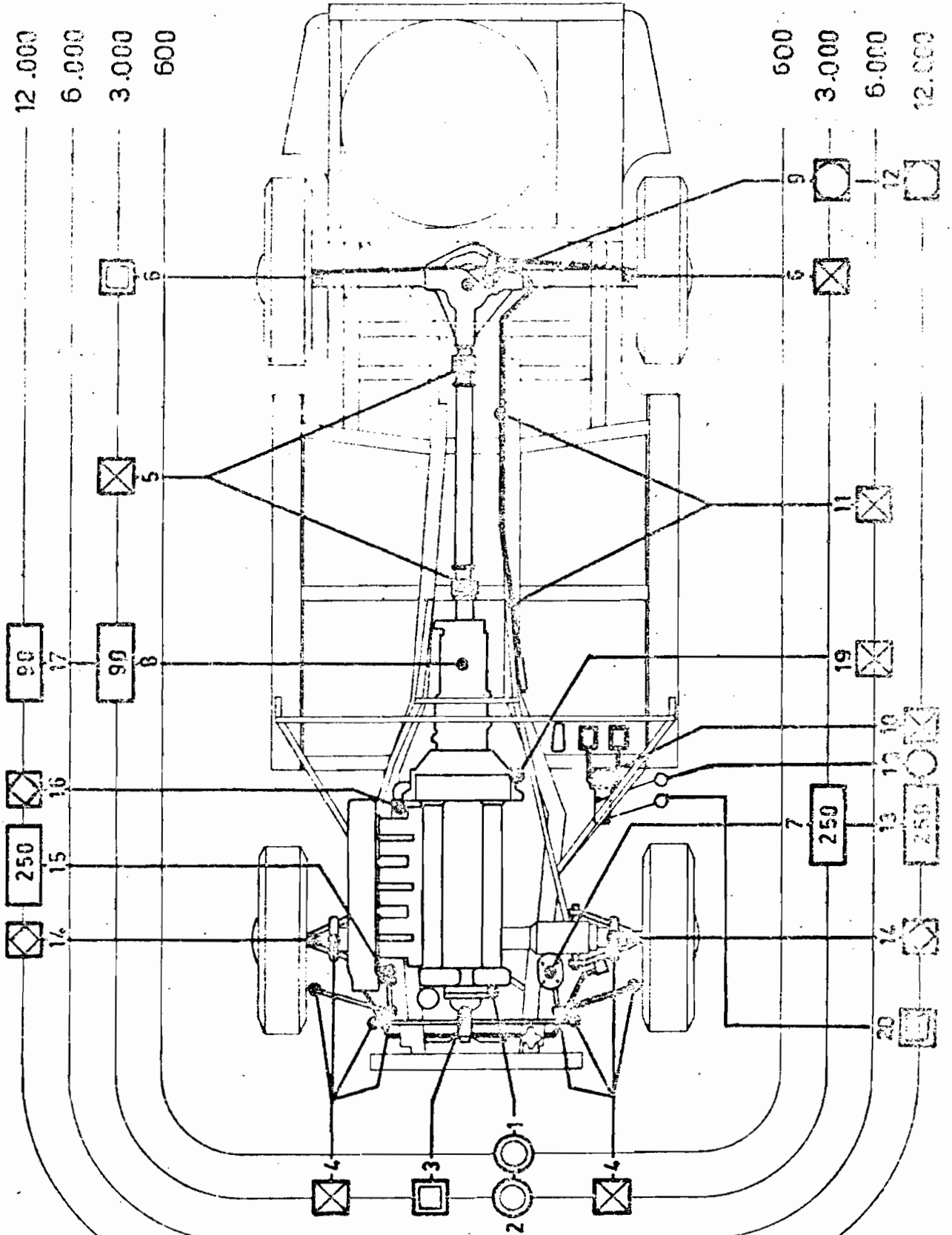



MAINTENANCE

The following is a list of the operations normally necessary for the proper maintenance of the car:

WEEKLY:

1. Engine: Check oil level and top up if necessary
2. Radiator: Check water level and add, preferably distilled, water if necessary.
3. Tyres: check pressure.

After every 2,500 miles, as above plus

4. Engine: renew oil and filter element
5. Lubricate water pump.
6. Lubricate front suspension joints.
7. Lubricate universal joints.
8. Lubricate steering and ball joints; check oil level in steering box.
9. Lubricate rear hubs.
10. Check level of clutch fluid and top up if necessary.
11. Check level of battery and add distilled water if necessary.
12. Check level of brake fluid and top up if necessary.
13. Clean sparking plugs: and check gap between points.
14. Clean contact breaker points: and check clearance.
15. Check tension of fan belts.
16. Check tension of timing chain: and adjust if necessary.
17. Examine water pump seal: for possible leakage in gasket and renew, if necessary.
18. Check clutch pedal clearance: make sure there is 3/8" free travel before pedal pressure.
19. Brakes: make visual check for wear.
20. Steering box; check clearance.

6,000 Miles all above plus

21. Change gear box oil.
22. Change oil in rear axle.
23. Check tappet clearances
24. Handbrake: lubricate the outer cable.
25. Renew petrol filter elements in pump and filter at bottom of tank.
26. Thrust clutch shaft: lubricate.

12,000 Miles all above plus

27. Steering Box: change oil completely.
28. Front hubs pack with grease.
29. Renew oil filter in injection distributor.

FURTHER INFORMATION CONCERNING THE FOLLOWING ADJUSTMENTS:8 - 15 - 16 - 18 - 19 - 25 - PROCEED AS FOLLOWS:

8. Steering: During the appropriate service a thorough examination should be made of the steering assembly including cleaning and lubricating the joints of the tie-rods and the main steering unit in the steering box.
15. Dynamo belt: To adjust the belt, loosen the nut on the bracket holding the dynamo at the base and adjust the tension of the belt by altering the position of the alternator itself.
16. Timing chain: If, after a certain time, it becomes necessary to tighten the chain, slacken the centre nut, remove the washer and shim beneath, using the extractor provided. Turn the pulley, and block it in the required position by means of the shim and the two sets of holes. Then tighten washer and nut.
18. Clutch adjustment: The clearance between the clutch plate and disc must be approx.  $3/32$ ".
19. Disc brakes: Ensure that the surfaces of the disc are parallel to the inside face of the brake pads. A tolerance of a few hundredths of a millimetre only is permissible. The brake pads should be renewed every 12500 miles.
25. Petrol filters: It must not be overlooked that there are three filters in the petrol circuit.
1. Nylon filter in the lower part of the right hand tank.
  2. A paper cartridge filter in the pump.
  3. A felt filter in the injection distributor.
- The wire gauze does not require renewal. The nylon filter should be examined and if necessary cleaned with petrol and after every 5,000 miles. The cartridges must be renewed, keeping the pump in a vertical position. (In addition to the cartridges, renew the sealing ring every 10,000 miles and the felt filter after every 15,000 miles.)



DIMENSIONS IN INCHES

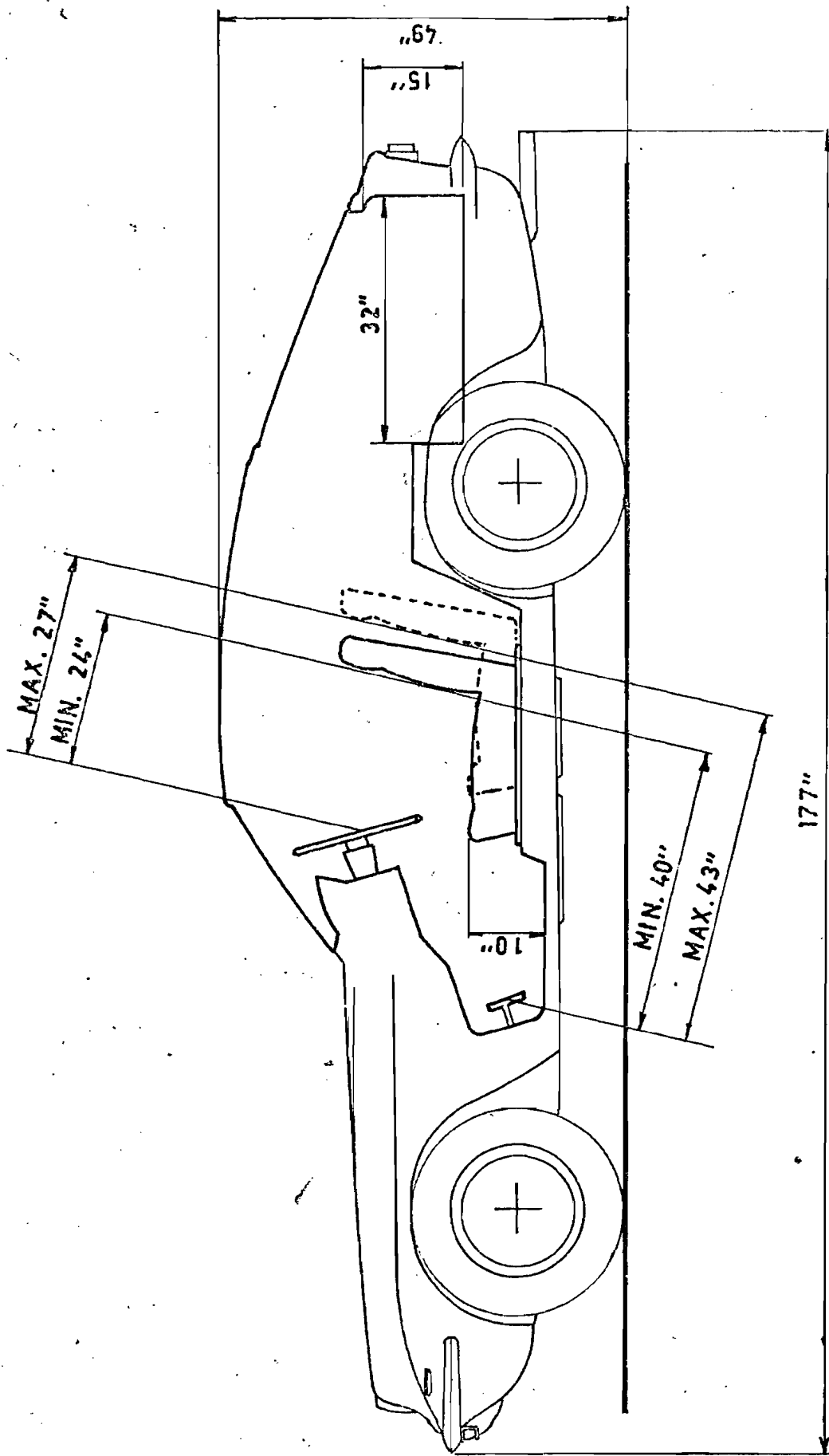

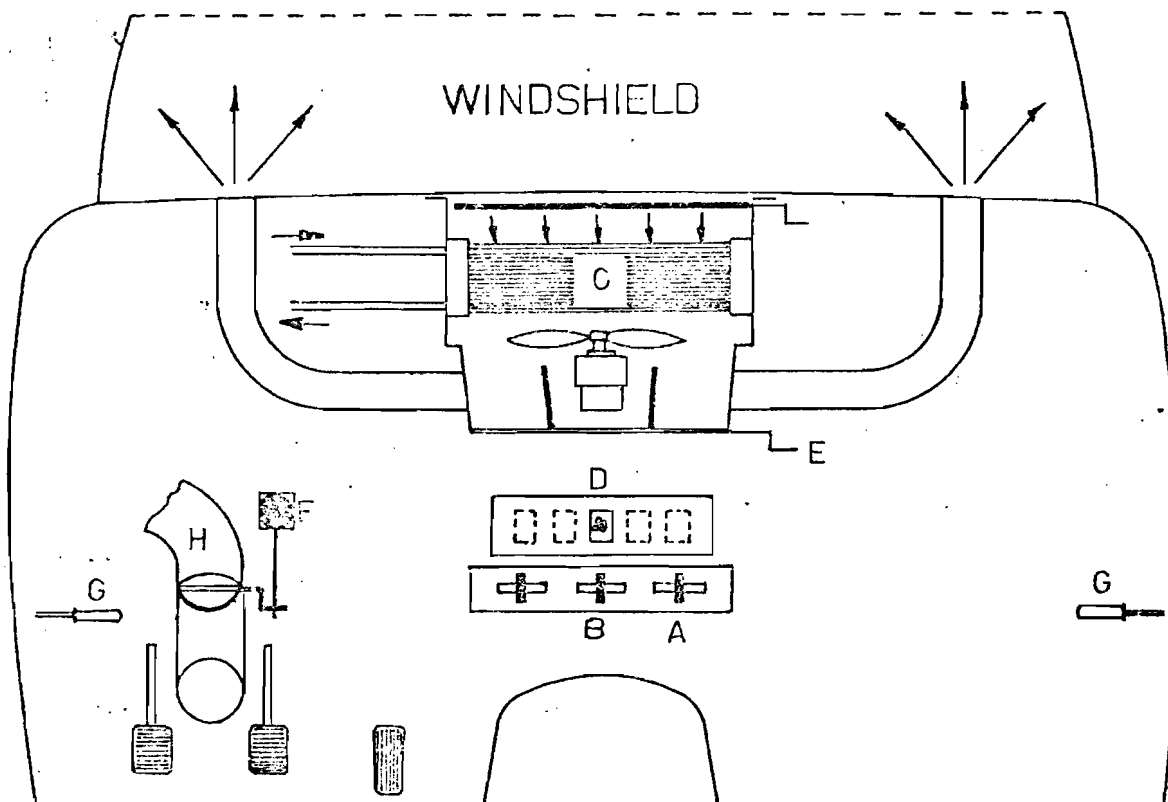

### HEATING AND VENTILATING SYSTEM

#### VENTILATING SYSTEM

Apart from air entering via the deflectors and the door lights, the intake of air is controlled by moving to the right the lever A which controls the opening of the air vent above the bonnet. The volume of air admitted, especially when the car is travelling at slow speeds, can be increased by starting the electric fan controlled by the switch D. A second air inlet H, at the front, by the driver's feet, provides fresh air, which can be regulated by means of the knob F. There are also two apertures, at the sides of the car and these provide additional ventilation when required. They are controlled direct from the inside by knob G.

#### HEATING SYSTEM

To obtain hot air inside the car and to prevent misting of the windscreen open first water outlet taps(2) inside engine compartment, then move lever B to the left to obtain circulation of the hot water in the heating radiator C and move lever A which allows air to pass through the radiator.



To increase the air speed, start the fan by means of switch D.

By opening vent E, maximum air intake into the car is provided. By keeping the vent partly open, or closing it completely, part or all the hot air is directed toward the windshield.

#### STANDARD TOOLS

The tool kit supplied with car as standard equipment contains:

- 1 Jack
- 1 Set of to 22 mm. fixed head spanners
- 1 Sparking spanner
- 1 Sparking plug box spanner
- 1 Carburettor spanner
- 1 Curved road wheels spanner
- 1 Steel hammer
- 1 Universal pair of pincers
- 1 Screwdriver

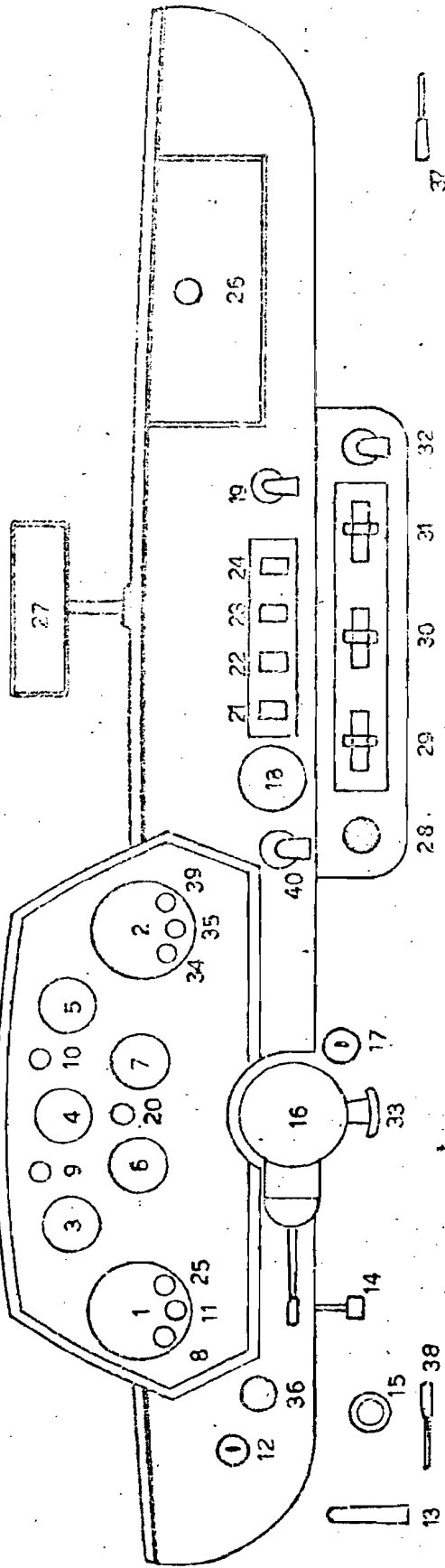

- 1 Speedometer
- 2 Revolution counter
- 3 Water temperature gauge
- 4 Petrol gauge
- 5 Oil pressure gauge
- 6 Ammeter
- 7 Oil temperature gauge
- 8 Fan Warning light
- 9 Petrol warning light
- 10 Handbrake warning light
- 11 Fuel starter warning light
- 12 Starter switch
- 13 Bonnet release
- 14 Speedometer trip adjustment
- 15 Windscreen washer
- 16 Floorers, light switch, horn, controls
- 17 Anti-theft device
- 18 Watch
- 19 Windscreen wiper switch
- 20 Yellow warning light for rear glass resistance
- 21 Headlamps "main beam" switch
- 22 Fan switch
- 23 Interior roof light switch
- 24 Alternator warning light
- 25 Glove box
- 26 Rear view mirror
- 27 Cigar lighter
- 28 Choke (open: lever in 1 h. position)
- 29 Water circulation control, hot water (on: lever to left)
- 30 Air control to radiator (open: lever to right)
- 31 Instrument light switch
- 32 Steering wheel adjustment
- 33 Headlamps warning light
- 34 Side lamp warning light
- 35 Driver's air control
- 36 Passenger's air control
- 37 Position light warning light
- 38 Switch for rear glass resistance

- 6 Right side indicator lamp
- 7 Electric horns , diaphragm type
- 8 Pneumatic horns with electric compressor
- 9 Heater switch for controls electromagnetic fan
- 10 Relay engine fan controls for cooling condenser
- 11 Electromagnetic clutch for fan drive
- 12 Water temperature transmitter
- 13 Coil ignition and distributor
- 14 Bonnet lamp
- 15 Electromagnetic clutch-compressor controls
- 16 High pressure switch for compressor controls
- 17 Generator alternator
- 18 Oil temperature transmitter
- 19 Oil thermal pressure transmitter
- 20 Ignition coils
- 21 Starter motor
- 22 Hydraulic switch for stop lights
- 23 Windscreen wiper motor
- 24 Engine
- 25 Heater fan
- 26 Fan and radiator for air-conditioning installation
- 27 Main connection-electrical installation
- 28 Voltage regulator for alternator
- 29 Petrol injection pump
- 30 Alternator and regulator ground connection
- 31 Red warning light for fuel tank reserve
- 32 Red warning light for "handbrake on"
- 33 Voltage regulators for panel instruments
- 34 Water temperature gauge
- 35 Petrol level gauge
- 36 Oil pressure gauge
- 37 Ammeter
- 38 Oil temperature gauge
- 39 Speedometer with :
  - a) Yellow warning light for heater fan
  - b) Green warning light for "starter on"
  - c) Red warning light for alternator controls
- 40 Revolution counter with :
  - a) Bleu warning light for headlamp (main beam position)
  - b) Red warning light - direction indicator
  - c) Green warning light for parking light
- 41 Sliding contact controls for pneumatic horns
- 42 Headlamps and direction indicator controls
- 43 Electric clock



- 44 Parking lights and dipper light controls switch
- 45 Headlamps main - beam control switch
- 46 Heater fan control switch
- 47 Roof light control switch
- 48 Windscreen wiper control switch
- 49 Cigar lighter
- 50 Pushbutton "starter on"
- 51 Instrument panel light control switch
- 52 Radio receiver
- 53 Aerial movement control
- 54 Horns - remote control
- 55 Direction indicator control switch
- 56 Starter and signal switch
- 57 Pump for windscreen wiper motor
- 58 Relay switch main - beam
- 59 Switch for left door
- 60 Left window regulator engine
- 61 Warning lamp on left door
- 62 Pushbutton switch "handbreke on"
- 63 Reversing lights switch
- 64 Left door control switch
- 65 Right door control switch
- 66 Lamp on ash receptacle
- 67 Fuse box
- 68 Switch for right door
- 69 Right window regulator engine
- 70 Warning light on right door
- 71 Battery
- 72 Roof light fitting
- 73 Screw clamp for rear connection
- 74 Automatic aerial with electric motor incorporated
- 75 Luggage boot light fitting
- 76 Pushbutton switch for luggage boot light
- 77 Loudspeaker
- 78 Petrol level indicator float
- 79 Left rear lamp (three lights) :
  - a) Direction indicator
  - b) Parking and stop light
  - c) Reversing light
- 80 Number plate lights
- 81 Right rear lamp (three lights) :
  - a) Direction indicator
  - b) Parking and stop lights
  - c) Reversing light





MAIN FUSEBOX

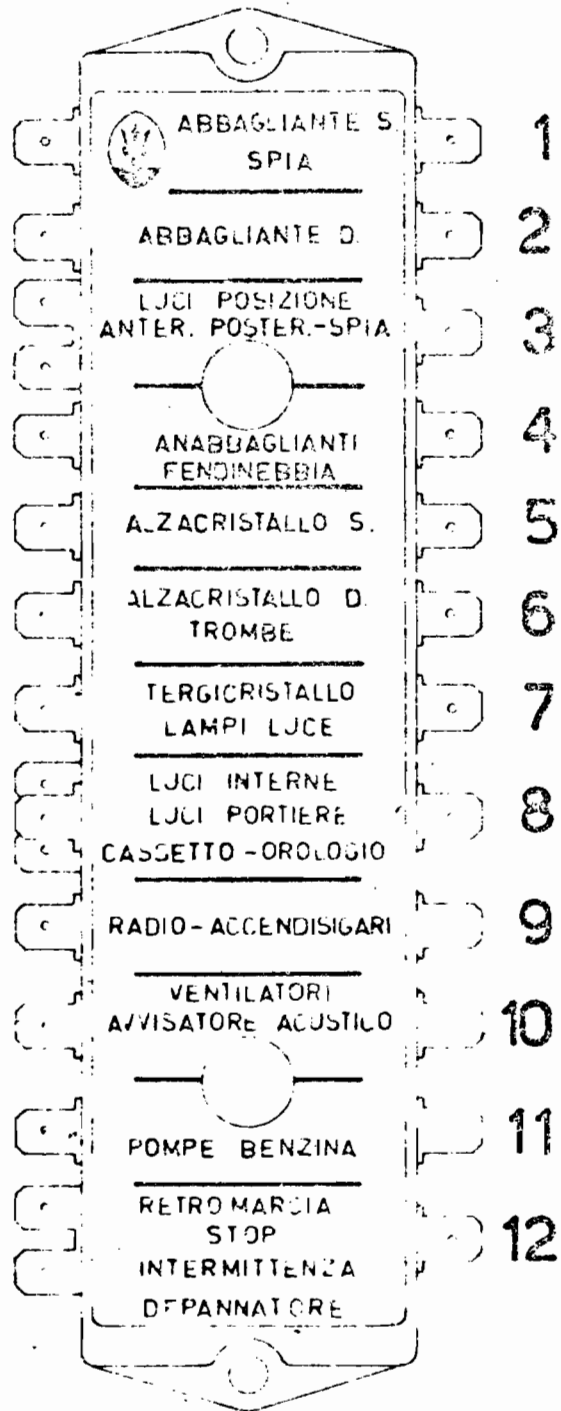

MAIN FUSEBOX

- 1 - Left headlamp main beam warning light.
- 2 - Right headlamp main beam
- 3 - Front/rear side lamps - warning light.
- 4 - Dipped light headlamps, fog lamps.
- 5 - Left window winder motor.
- 6 - Right window winder motor, air horns.
- 7 - Windscreen wiper, headlamp flashing lights.
- 8 - Inside lights, door lights, glove box and clock lights.
- 9 - Radio and cigar lighter.
- 10 - Fans, horn.
- 11 - Fuel pumps.
- 12 - Reverse driving lamps, stop lights, direction indicator flashing lights, rear window defroster.